

Physical Specification

Nominal Voltage		12.8V
Nominal Capacity (10Hr)		5.0 Ah
Dimension	Length	150±2mm (5.91 inches)
	Width	66±2mm (2.60 inches)
	Container Height	130±2mm (5.12 inches) Total
	Height (with Terminal)	130±2mm (5.12 inches)
Weight	Approx 0.94kg (2.0lbs)	



- * Motorcycle Li-ion battery
- * Maintenance-free
- * Real-time protection (overcharge, over-discharge, over-temperature) and energy balance of battery system through BMS
- * Powerful 150 cold cranking amps
- * Shipped pre-charged and ready to install
- * Replaces YT12B-BS/YT14B-BS/YB16AL-A2 battery

Electrical Specification

Rated Capacity	0.1C rate (0.5A)	5.0Ah
	0.5C rate (2.5A)	5.0Ah
	10C rate (50.0A)	4.5Ah
	60C rate (300.0A)	3S
Capacity affected by Temperature	40 °C (104 °F)	98%
	25 °C (77 °F)	100%
	0 °C (32 °F)	85%
	-20 °C (-4 °F)	60%
Self Discharge	Approximately 1.5% per month (25°C (77°F))	
Charging Methods	Constant-Voltage Charge:	
	Full Charge Initial charging current: less than 2.5A Voltage: 14.40 V ~ 14.60 V at 25 °C (77 °F)	

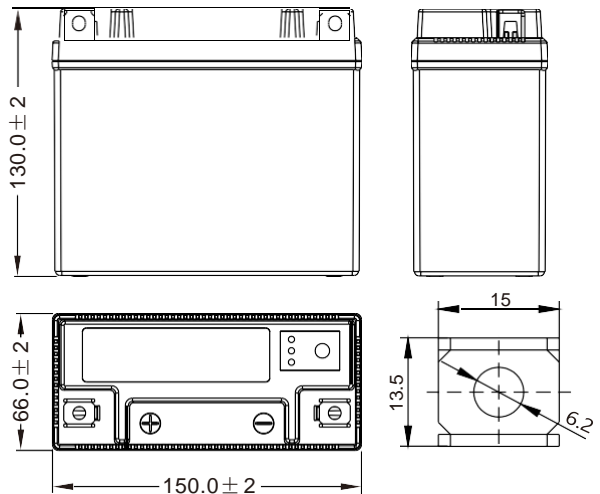

Dimensions (mm)

Curve Specification

