

Lithium Battery - Forklift Series

MKS-FP24100(25.6V100Ah)



Features Of LiFePO4 Battery

- Long cycle life
- High integration, small size, high energy density
- Intelligent management of product usage status with high security
- Environmental protection
- Capable of 1C fast charging

Application scenarios

- Forklift
- Lead-acid battery to lithium battery vehicles
- Industrial control products
- Rescue vehicles such as scissor forklifts



Specification

Nominal Voltage	25.6V
Working Voltage	20V-28.8V
Nominal Capacity	100Ah
Energy	2560Wh
Self Discharge	≤3% Per Month
IP Grade	IP56
Positive material	Lithium Iron Phosphate
Cell type	Square LFP
Weight	ABOUT 42KG
Dimension LxWxH	L645*W190*H540mm
Fixed size	NO
Terminal Type	REMA160 female
Shell type	Powder Coated Steel
Handle	YES
Storage Temp. short term	-20-45°C
Storage Temp. long term	0~35°C
Cycle Life	3000 cycles
Heating function	NO
Cooling type	NO
Balancing Voltage	No Limited
Wake up control	Push button switch

Charging

Rated Charge Current	50A
Upper limit Voltage	28.8V
Charging Temp. Range	0~55°C

DisCharging

Rated Discharge Current	100A
Max. Discharge Current	400A
Rated Discharge Cut-off Voltage	22V
Min.Discharge Cut-off Voltage	≥20V
Discharge Temp. Range	-20~60°C

Function (optional)

(CAN/RS485), Bluetooth, 4G, Screen, Charger

Physical Dimension-mm

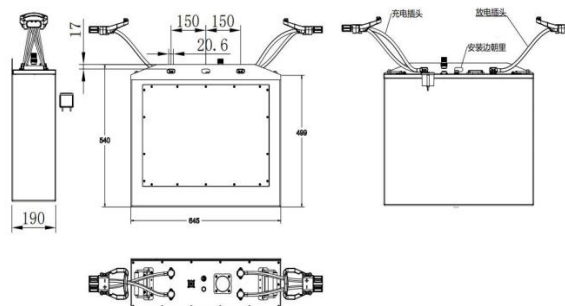

①