



# **LITHIUM IRON PHOSPHATE Battery for Telecomm User Manual**

Version: V1.0

Released Date: 2024-10-23

Document Number: LB-LFELI-48-EN-V1.0-20241023

# FOREWORD

---

## Overview

This manual describes product introduction, installation, use, maintenance, etc. Please read this manual before installing the battery and follow the instructions carefully during installation. If there is any confusion, please get in touch with the vendor immediately for advice and clarification.

## Readers

This document provides technical details regarding the tools and infrastructure used by the following users:





- Sales engineer
- Technical support engineer
- Installation engineer
- Application engineer
- Maintenance engineer

## Manual Lost

If you lose the manual, please contact the vendor's customer service center for the electronic files.

## Symbol convention

The following symbols may appear in this article, and they are represented as follows:

Symbol	Indication
 Dangerous	Used as warning in an emergency, if not avoided, it will result in death or serious personal injury.
 Warning	Used as a warning of a middle or low potential hazard, if not avoided, it may cause minor or normal injury.
 Caution	Used as a warning of potential dangers, if ignore this information, it may result in equipment broken, data lost, equipment performance decrease and other unpredictable result.
 INTRO	Represents the supplement information of main text to emphasize or replenish.

- i. It is important and necessary to read the user manual carefully (in the accessories) before installing or using the battery. Failure to do so or to follow any of the instructions or warnings in this document can result in electrical shock, serious injury, or death, or can damage the battery, potentially rendering it inoperable.
- ii. If the battery is stored for a long time, it is required to charge it every six months, and the SOC should be no less than 80%.
- iii. Battery needs to be recharged within 12 hours, after fully discharged. Do not install in an environment outside of the operation temperature or humidity range listed in the manual.
- iv. Do not expose the cable outside.
- v. Do not connect the power terminal reversely.
- vi. All the battery terminals must be disconnected for maintenance.
- vii. Please contact the supplier within 24 hours if there is something abnormal.
- viii. Do not use cleaning solvents to clean the battery.
- ix. Do not expose the battery to flammable or harsh chemicals or vapors.
- x. Do not paint any part of the battery, including any internal or external components.
- xi. Do not connect the battery with PV solar wiring directly.
- xii. Any foreign object is prohibited from being inserted into any part of the battery.

## Contents

<b>1 OVERVIEW</b> .....	<b>5</b>
1.1 Product specification .....	5
1.2 Product profiles .....	5
1.3 Product structure .....	6
<b>2 ILLUSTRATIONS</b> .....	<b>7</b>
2.1 Explanation of the structure.....	7
2.2 Panel description .....	7
2.3 LCD operation instructions .....	13
2.4 The working principle.....	15
2.5 The product features .....	16
<b>3 INSTALLATION GUIDE</b> .....	<b>18</b>
3.1 Installation precaution notes.....	18
3.2 Installation preparation .....	20
3.3 Mounting the battery.....	23
<b>4 MAINTENANCES</b> .....	<b>25</b>
4.1 Electrical maintenance.....	25
4.2 Battery maintenance.....	26
4.3 Trouble shooting steps .....	26
<b>5 TRANSPORTATION AND STORAGE</b> .....	<b>29</b>
5.1 transportation requirement.....	29
5.2 Storage .....	29
<b>6 ENVIRONMENT PROTECTION</b> .....	<b>31</b>
6.1 Environmental Label.....	31
6.2 Recycle.....	31

# 1 OVERVIEW

---

## 1.1 Product specification

The model of integrated lithium-Ion battery (hereafter referred to as lithium battery or PACK) for Rack-Mounted is shown in figure 1-1-1.

1-1-1 The explanation of the product specification (For example)

### LFELI – 48 100

①            ②            ③

① The main ingredient of Lithium-Ion battery is Lithium iron phosphate

② The voltage is 48 V

③ The capacity is 100Ah

## 1.2 Product profiles

LFELI series lithium iron phosphate battery is one of new energy storage products developed and produced. It can be used to support reliable power for various types of equipment and systems. Especially suitable for application scene of high power, limited installation space, restricted load-bearing and long cycle life.

LFELI series lithium iron phosphate battery has built-in BMS battery management system, which can manage and monitor cells information including voltage, current and temperature. What's more, BMS can balance cells charging and discharging to extend cycle life. Multiple batteries can connect in parallel to expand capacity and power in parallel for larger capacity and longer power supporting duration requirements.

## 1.3 Product structure

The appearance of the lithium battery pack is shown in figure 1-3-1, for interface description; please refer to the 2-1-1 panel description".

1-3-1 Product picture



# 2 ILLUSTRATIONS

## 2.1 Explanation of the structure

The structure of Lithium-Ion battery pack as shown in figure 2-1-1

Figure 2-1-1

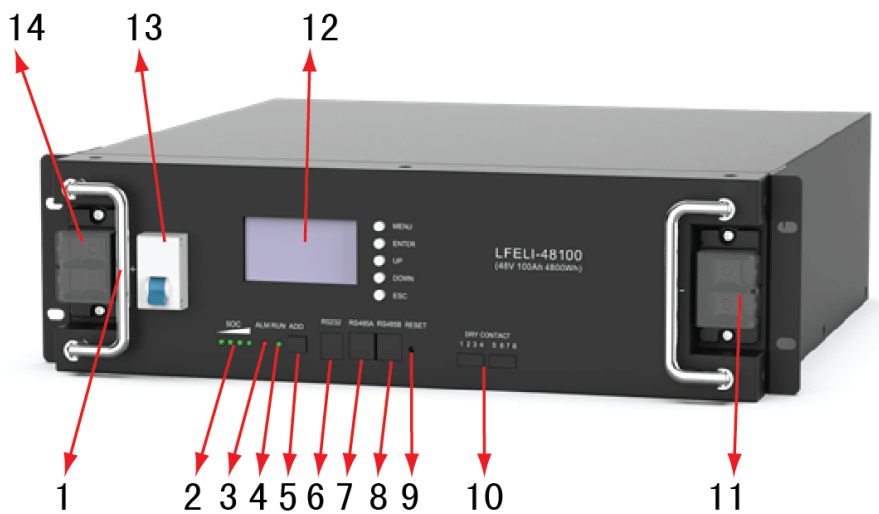

1. Handle	2.SOC (capacity light)	3.ALM (alarm)	4.RUN	5.ADD
6.RS232	7.RS485A	8.RS485B	9.RESET	10.Dry Contact
11.P+	12. Display	13. Breaker	14. P-	

## 2.2 Panel description

The panel of the module of the lithium battery pack, as shown in figure

## 2-1-1 Module panel description

### Out put

Using 4 pin terminal pins, the front of the terminal from left to right is defined as battery+, Battery+,



Battery-, battery-, which is connected with the power transmission line for charging and discharging.

### SOC

The meaning of SOC indication light is shown in table 2-2-1

Table 2-2-2 The relationship between the capacity of the battery and the light

☒ indicates LED is ON, ○ indicates LED is OFF.

●	●	●	●	Capacity
☒	☒	☒	☒	75%-100%
☒	☒	☒	○	50%-75%
☒	☒	○	○	25%-50%
☒	○	○	○	0%-25%

### ALM

When the battery is at alarm or fault, "ALM" light is red.

### RUN

During charging, the "RUN" light will be flashing.

"RUN" and "ALM" can display the battery status, as shown in table 2-2-2

Table 2-2-2 The explanation of "RUN" and "ALM"



PACK Status	Normal/Alarm/Protection	RUN	ALM	Remark
		●	●	
Power Off	Sleep	OFF	OFF	All off
Standby	Normal	Flash 1	OFF	Standby state
	Alarm	Flash 1	Flash 3	Cell low voltage
Charge	Normal	ON	OFF	
	Alarm	ON	Flash 3	
	Over Charge Protection	ON	OFF	Stop charge
	Temperature. Over-current. Fault Protection	OFF	ON	Stop charge
Discharge	Normal	Flash 3	OFF	
	Alarm	Flash 3	Flash 3	
	Under Discharge Protection	OFF	OFF	Stop discharge
	Temperature. Over-current. Short Circuit Fault Protection	OFF	ON	Stop discharge

Fault		OFF	ON	Stop charge Stop discharge
-------	--	-----	----	-------------------------------

Note: The flashing instructions, flash1-light 0.25s/off 3.75 seconds; flash2-0.5 slight /0.5s off; flash3-0.5 slight/1.5s off.

## ADD

In parallel, band switch uses six dip switches to address the set cell system. The explanation of its dial switch as shown in table 2-2-3.

Table2-2-3 DIP switch address code

PACK Definition	ADD	Address Code					
		#1	#2	#3	#4	#5	#6
Reserve	0	OFF	OFF	OFF	OFF	OFF	OFF
PACK 1	1	ON	OFF	OFF	OFF	OFF	OFF
PACK 2	2	OFF	ON	OFF	OFF	OFF	OFF
PACK 3	3	ON	ON	OFF	OFF	OFF	OFF
PACK 4	4	OFF	OFF	ON	OFF	OFF	OFF
PACK 5	5	ON	OFF	ON	OFF	OFF	OFF
PACK 6	6	OFF	ON	ON	OFF	OFF	OFF
PACK 7	7	ON	ON	ON	OFF	OFF	OFF
PACK 8	8	OFF	OFF	OFF	ON	OFF	OFF
PACK 9	9	ON	OFF	OFF	ON	OFF	OFF
PACK 10	10	OFF	ON	OFF	ON	OFF	OFF
PACK 11	11	ON	ON	OFF	ON	OFF	OFF
PACK 12	12	OFF	OFF	ON	ON	OFF	OFF
PACK 13	13	ON	OFF	ON	ON	OFF	OFF
PACK 14	14	OFF	ON	ON	ON	OFF	OFF
PACK 15	15	ON	ON	ON	ON	OFF	OFF
PACK 16	16	OFF	OFF	OFF	OFF	ON	OFF
PACK 17	17	ON	OFF	OFF	OFF	ON	OFF
PACK 18	18	OFF	ON	OFF	OFF	ON	OFF
PACK 19	19	ON	ON	OFF	OFF	ON	OFF
PACK 20	20	OFF	OFF	ON	OFF	ON	OFF
PACK 21	21	ON	OFF	ON	OFF	ON	OFF
PACK 22	22	OFF	ON	ON	OFF	ON	OFF
PACK 23	23	ON	ON	ON	OFF	ON	OFF
PACK 24	24	OFF	OFF	OFF	ON	ON	OFF
PACK 25	25	ON	OFF	OFF	ON	ON	OFF
PACK 26	26	OFF	ON	OFF	ON	ON	OFF
PACK 27	27	ON	ON	OFF	ON	ON	OFF
PACK 28	28	OFF	OFF	ON	ON	ON	OFF
PACK 29	29	ON	OFF	ON	ON	ON	OFF
PACK 30	30	OFF	ON	ON	ON	ON	OFF
PACK 31	31	ON	ON	ON	ON	ON	OFF

PACK 32	32	OFF	OFF	OFF	OFF	OFF	ON
PACK 33	33	ON	OFF	OFF	OFF	OFF	ON
PACK 34	34	OFF	ON	OFF	OFF	OFF	ON
PACK 35	35	ON	ON	OFF	OFF	OFF	ON
PACK 36	36	OFF	OFF	ON	OFF	OFF	ON
PACK 37	37	ON	OFF	ON	OFF	OFF	ON
PACK 38	38	OFF	ON	ON	OFF	OFF	ON
PACK 39	39	ON	ON	ON	OFF	OFF	ON
PACK 40	40	OFF	OFF	OFF	ON	OFF	ON
PACK 41	41	ON	OFF	OFF	ON	OFF	ON
PACK 42	42	OFF	ON	OFF	ON	OFF	ON
PACK 43	43	ON	ON	OFF	ON	OFF	ON
PACK 44	44	OFF	OFF	ON	ON	OFF	ON
PACK 45	45	ON	OFF	ON	ON	OFF	ON
PACK 46	46	OFF	ON	ON	ON	OFF	ON
PACK 47	47	ON	ON	ON	ON	OFF	ON
PACK 48	48	OFF	OFF	OFF	OFF	ON	ON
PACK 49	49	ON	OFF	OFF	OFF	ON	ON
PACK 50	50	OFF	ON	OFF	OFF	ON	ON
PACK 51	51	ON	ON	OFF	OFF	ON	ON
PACK 52	52	OFF	OFF	ON	OFF	ON	ON
PACK 53	53	ON	OFF	ON	OFF	ON	ON
PACK 54	54	OFF	ON	ON	OFF	ON	ON
PACK 55	55	ON	ON	ON	OFF	ON	ON
PACK 56	56	OFF	OFF	OFF	ON	ON	ON
PACK 57	57	ON	OFF	OFF	ON	ON	ON
PACK 58	58	OFF	ON	OFF	ON	ON	ON
PACK 59	59	ON	ON	OFF	ON	ON	ON
PACK 60	60	OFF	OFF	ON	ON	ON	ON
PACK 61	61	ON	OFF	ON	ON	ON	ON
PACK 62	62	OFF	ON	ON	ON	ON	ON
PACK 63	63	ON	ON	ON	ON	ON	ON



The number of DIP switches depends on the product received. For 4 DIP ADD, the max is 15 in parallel, for 6 DIP ADD, the max is 63 in parallel.

## RS232

The system uses RS-232 series load data for Telecommute, transferring data including: system parameters, system status and alarm information.

Connected with a high-end computer, only when the dip switch is set to Pack (Master Pack Recommended DIP ADD1) mode, the RS-232 Telecommute module is effective. Connection as shown in figure 2-2-4

2-2-4 RS-232 connection schematic diagram

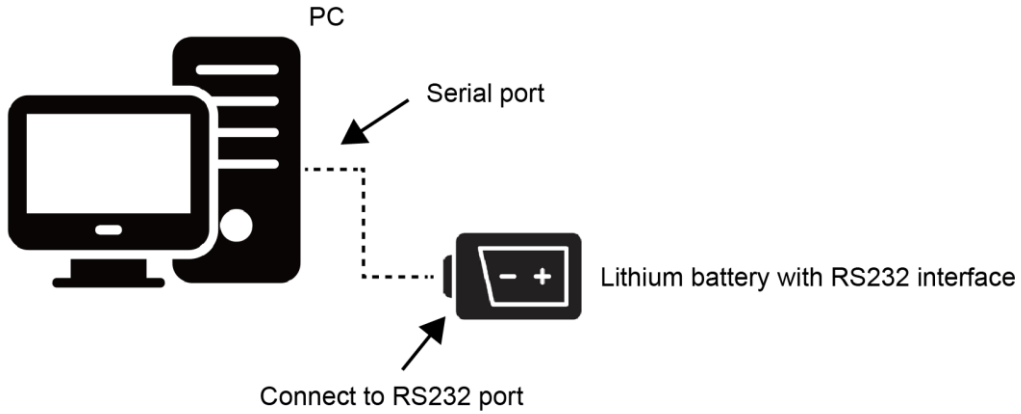

## RS485

When the system is in parallel mode, it can use the RS-485 serial Telecommute for data transfer. Connection as shown in figure 2-2-5.

2-2-5 RS-485 connection schematic diagram

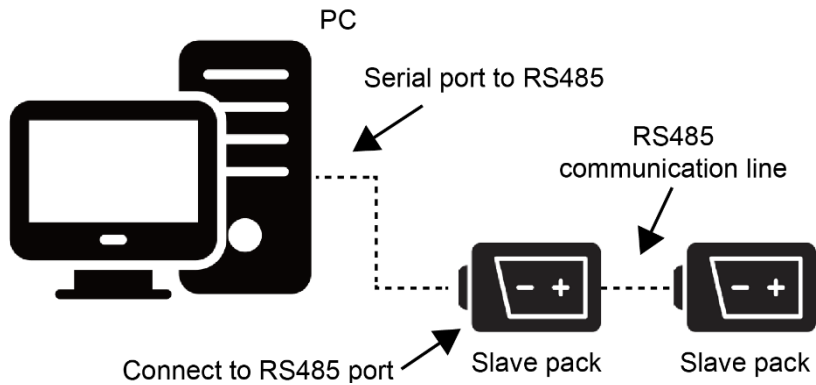

PC to Battery		Battery to battery Or PC to Battery	
RS232		RS485A, RS485B	
PIN	Definition	PIN	Definition
1	NC	1	RS485-B
2	NC	2	RS485-A

3	TX	3	GND
4	RX	4	NC
5	GND	5	NC
6	NC	6	GND
		7	RS485-A
		8	RS485-B

## Dry Contact Terminal

Dry Contact Terminal: provided 2 ways input and 2 ways output dry contact signal.

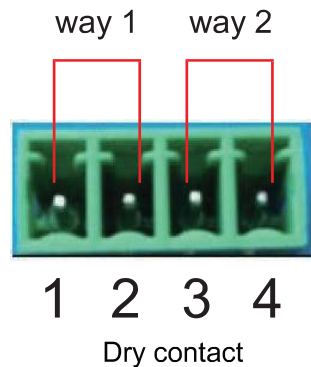

## RESET

Press RESET key for 3~6 seconds, then start the device, press the RESET key for 3~6 seconds again, then shut down the device. When the system is running, should there be an exception, use this button to reset the system (press / release) to ensure the stability of the system.

## 2.3 LCD operation instructions

The LCD display interface is user-friendly, as shown in figure 2-3-1. The LCD is able to display the alarm information in real time, and provides the historical warning records for the user to query, and provide a reliable basis for fault diagnosis.

Users can easily browse the battery parameters through the LCD interface, and obtain timely access to information on the current state of the battery. The interface displays a total of 4 menu keys, the functions described as follows.

### 2-3-1 LCD Display

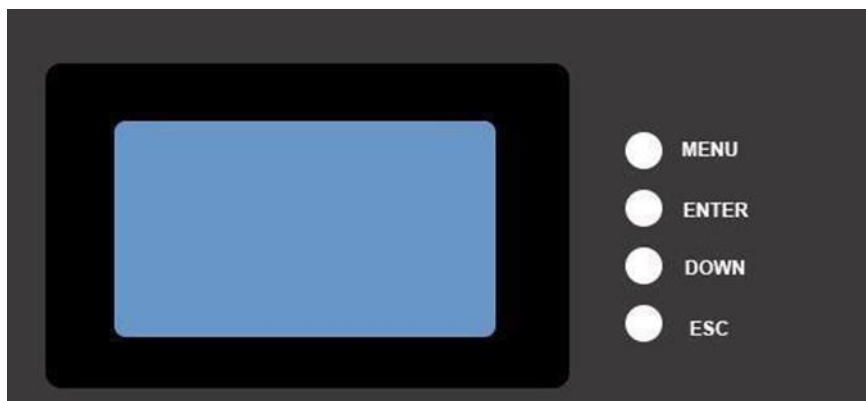

The commonly used button function

The display function of the button as shown in table 2-3-2.

Button function description

MENU	Main menu
ENTER	Confirm, enter
DOWN	Page down
ESC	Return, launch

## Operation procedures

1) Press "MENU" once, the LCD display screen light up, then the welcome interface will be shown.



2) Followed by the prompt and then click once to enter the main menu bar.

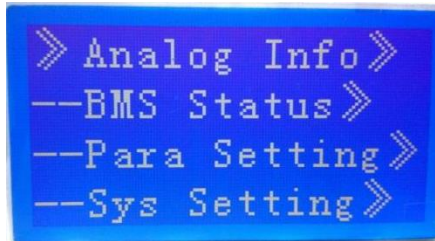

3) Scroll page up and page down “DOWN “, Enter the Menu screen, when the arrow



points to the corresponding bar, press Enter “ENTER” to confirm.

4) Go back on the menu bar, click “ESC”.

## 2.4 The working principle

Lithium battery pack is equipped with charging and discharging management module and monitoring module.

Charge and discharge management module protects battery charge and discharge functioning, prevents overcharging, discharge over-current, the charging process by the adapter charger to the DC input form, the discharge process is completed by connecting the load discharge.

The monitoring module has the balance function and power, temperature and SOC. The monitoring module transmits the real-time information collected in the operation of the product through the Telecommute protocol network to the monitoring platform, and the user can observe the operation status of the battery in each group through the display screen.

A single module has a 48V (100) Ah, with a large capacity, As shown in figure 2-4-1

2-4-1 the working principal diagram

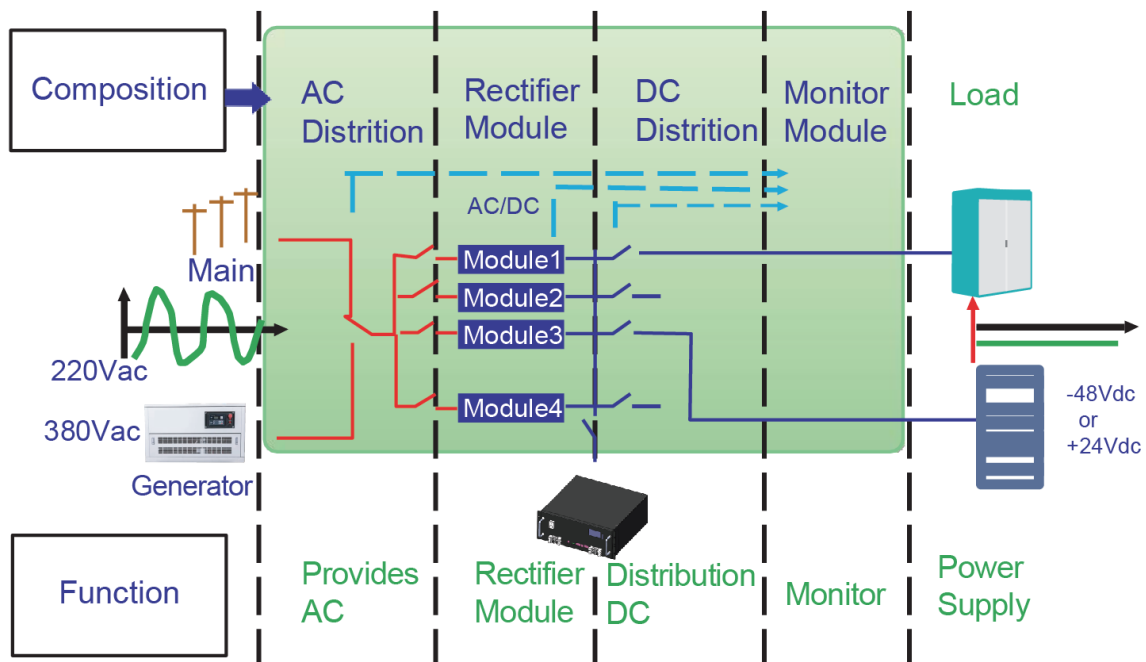

## 2.5 The product features

Integrated lithium battery pack for Rack-Mounted has the following remarkable characteristics:

- The whole module is non-toxic, non-polluting and environmentally friendly;
- The system can automatically manage charge and discharge state and balance current and voltage of each cell;
- Flexible configuration, multiple battery modules can be in parallel for expanding capacity and power
- Adopted self-cooling mode rapidly reduced system entire noise;
- The module has less self-discharge, up to 6 months without charging on shelf; no memory effect, excellent performance of shallow charge and discharge;
- Working temperature range is from -20°C to 60°C, (Charging 0~55°C; discharging -20~60°C) with excellent discharge performance and cycle life;
- Small size and light weight, standard of 19-inch embedded designed module is comfortable for installation and maintenance;

### INTRO

- Telemetry: voltage, current, temperature, SOC, SOH (optional), etc.



- Tel-signaling state of charge and discharge, overcharge / over-current, under voltage over-current alarm / alarm, environment / battery /PCBA/ battery temperature alarm, low environmental temperature alarm, battery capacity is too low, the battery temperature /voltage / current sensor failure alarm, battery failure alarm (just not cut off the monomer pressure high limit alarm) (optional), battery failure alarm (optional).
- Remote control: charge / discharge (optional), alarm sound off, intelligent intermittent charging mode, current limiting charging mode.
- Optional: Battery charge / discharge management parameters and the output parameters of the switching power supply system.

# 3

## INSTALLATION GUIDE

---

### 3.1 Installation precaution notes

- Comply with local laws and regulations

When operating the equipment, make certain to comply with local laws and regulations.

- Personnel requirements

Technicians who are responsible for installation and maintenance are required to undertake strict training at first. Master the correct methods for operation and safety, only then the installation, operation and maintenance can be carried out.

In order to maximize the efficiency of the equipment, to obtain best possible operating results, and ensure maximum lifespan, please pay careful attention to the correct installation and usage requirements.

- Personal safety

Insulated tools and gloves should be used and worn at all times – During the installation process, watches, bracelets, rings and other metal products should be removed.

Avoid any fall or collision during the installation process.

Do not remove the battery components. The maintenance of the battery should be carried out by a professional engineer.

Should be operated and supervised by engineer who have experience and can take preventive measures for potential hazards of battery.

Terminal	Recommended torque value
M5	$4\pm 0.5\text{N}\cdot\text{M}$
M6	$5.5\pm 0.5\text{N}\cdot\text{M}$
M8	$8\pm 0.5\text{N}\cdot\text{M}$

- Field and environment

Site requirements

- 1) Cleanliness

Lithium battery packs cannot be placed in or near garbage disposals, or accidentally dropped or

placed in smaller disposal units, as their interaction with metals is likely to cause short circuits and endanger the system and personal safety.

## 2) Fire protection

The room is prohibited to store flammable, explosive and other dangerous goods, and it should be equipped with effective fire equipment (such as CO<sub>2</sub> fire extinguishers).

## 3) Ventilation and heat dissipation

In order to facilitate the operation and maintenance of equipment for the heat, the equipment should be left around (50~30) cm around at least, left about 50cm for the upper space. The space should be equipped with exhaust fan, to maintain good indoor ventilation.

## 4) Installation requirements

Installation should be carried out as shown in figure 3-1-1 in order to avoid possible risks.

Put the lithium battery on the ground (to avoid tilt, uneven ground).

Avoid placing in the sunlight, rain or wet surfaces.

Figure 3-1-1 Requirements for installation scenarios

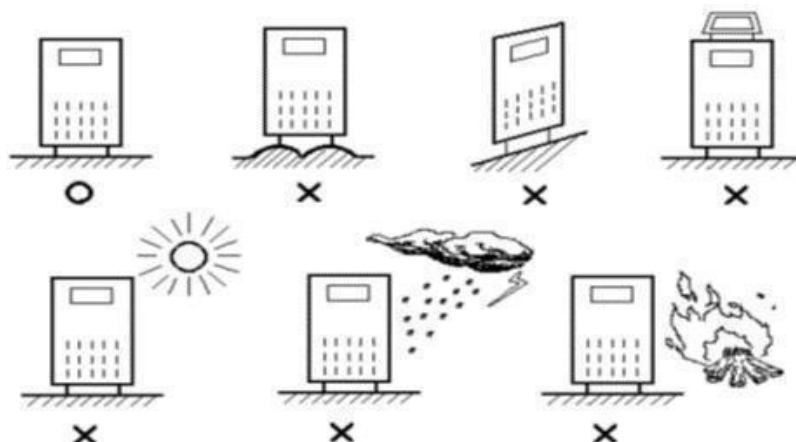

### ● Environmental

requirements Ambient temperature: ( -10~+40) °C.

Relative humidity level: 5%RH~95%RH, no condensation. Cooling method: air cooler.

Height above sea level: match to the standard requirement of GB3859.2-93. Versatility: no vibration and the vertical inclination does not exceed 5°.

Pollution level: Level 2.

Recommended operating temperature (20~25) °C, humidity level control within 50%.



Do not install in the working environment with metal conduction type dust.

Do not put anything containing corrosive gases.

Do not put anything in the dust concentrated areas.

Do not place any items on the top of lithium-ion battery pack. People could not sit on the battery.

- Power check

Before installation, please confirm that the load capability of inlet wire meets the requirements of the new equipment. Check to see if the power supply corresponds to the equipment nameplate of the voltage and frequency and if the current capacity has decreased due to the aging of the wire.

If in doubt, please check with your local power supply consultation department.

- Ground wire

Earthing terminal is ready; zero voltage required in the room cannot exceed 5V. DC output voltage and load capacity

Lithium-ion battery pack of rated DC output 48V.

When installing the lithium-ion battery pack, the user should check the lithium-ion battery pack in advance to make sure that the contacts and connectors are safely in place to avoid an open circuit or short circuit fault.

During installation, do not connect the lithium batteries polarity in reverse or in any way incorrectly, to avoid causing a short circuit.

Please do not connect the terminals with no security or insulation protection, so as to avoid the risk of electric shock.

## 3.2 Installation preparation

### ■ Unpacking and inspection

Lithium batteries and accessories use packaging of cardboard boxes or wooden boxes. When unpacking, be careful when dismantling. Inspect the device and accessories according to the package list, to ensure its complete and make certain nothing was damaged during shipping.

Before clearing the packaging, make sure that all parts are included. If equipment or accessories are damaged in transit, or incomplete or incompatible,

the equipment, accessories and order contracts should be recorded and local branches or offices should be contacted immediately.

The site needs to be tidied and inspected once again to make sure the audit documents are in order for the audit. Before inspection, the site should be clean.

## ■ Installation tools

Potential commonly used tools as shown in table 3-2-1~3-2-4 the field technician will increase or decrease the amount according to the construction.

Table 3-2 -1 General purpose tools













The appearance of the tools, parameters, and names			
Adjustable wrenches	Phillips's screwdriver	Slotted screwdriver	Socket wrench
			
Torque wrench	Open-end wrenches	Double offset ring spanner	Diagonal cutting pliers
			
Wire cutters	Needle nosed pliers	Marking pen	Working gloves
			
Ladder (2m)	Flashlight	Tape measure	Impact drill
			

Table 3-2-2 Tools for delivery and unpacking

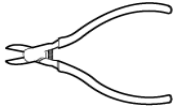

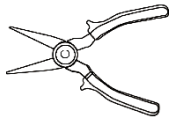
The appearance of the tools, parameters, and names			
Manual forklifts	Electric forklift	Sling weight $\geq$ 400kg )	Leverage (weight $\geq$ 400kg)
			

Table 3-2-3 Electrical installation tools

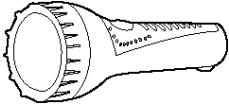
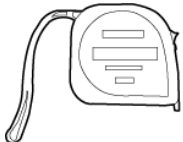
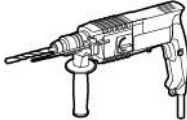
The appearance of the tools, parameters, and names			
Insulated gloves	Power cable crimping pliers	Wire stripping pliers	Electrical tape
			

Table 3-2-4 Measuring Tools

The appearance of the tools, parameters, and names			
Clamp meter			-
			-

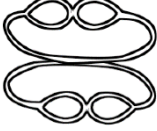
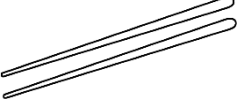
## 3.3 Mounting the battery

### ■ Single installation

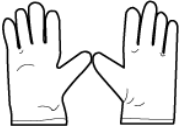
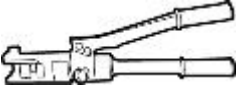
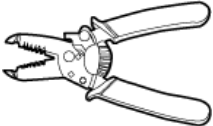
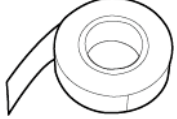
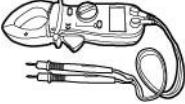
Single installation as shown in figure 3-3-1

Figure 3-3-1



— Positive power cable  
— Negative power cable

### ■ Multiple sets of parallel installation

Lithium batteries of 48V (10~100) Ah, with a variety of capacity modules, can be carried out according to the requirements for the parallel sets of batteries.

For parallel sets of batteries, no more than 8 groups, as shown in figure 3-3-2

### 3-3-2 Sketch map of parallel Installation

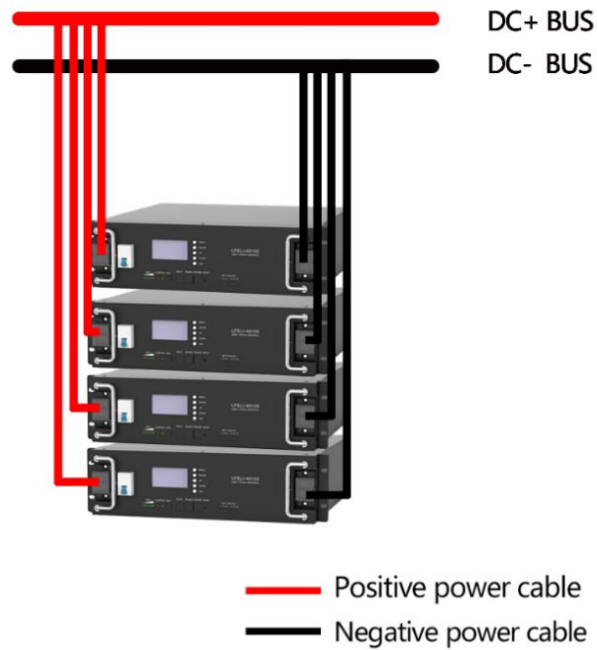

- Before the parallel installation, setting the battery to the limited charging mode is very important.
- Capacity load (namely in therewith voltage hysteresis current load), to ensure the work, start the power supply module first, then load.



# 4 MAINTENANCES

In order to ensure the lithium-ion battery pack achieves the longest life cycle, the maintenance technician should carry out regular inspections and maintenance care.

The maintenance records should be complete and routine, so that subsequent verification of management parameters of the battery pack can be tracked.

## 4.1 Electrical maintenance

Maintenance of the electrical parts may refer to table

Table 4-1 -1 Table of contents for maintenance

Items	The checking Points	Methods	Repair conditions	Repair solution
Electrical	Check if the Output of the voltage is normal	Multimeter	Battery voltage out of range set	See the following troubleshooting section
Fault inspection	Check if lights are normal	Visual inspection	Alarm	
Cable	Insulation, Terminal	Visual inspection	Insulation cracks, aging Exfoliated, corrosion of the terminals	Replace the cable Replace the terminal block

## 4.2 Battery maintenance

Table 4-2-1 Contents of battery maintenance

Frequency	Items	Solutions
Quarterly	Operating environment	Stay away from heat source and avoid direct sunlight.
	Visual inspection	If there is any breakage, leakage or deformation, isolate the problematic battery pack, take a photograph and replace the battery.
Annual	Visual inspection	Use cotton cloth to clean the appearance. Be careful during cleaning because the voltage is high.
	Connection status	Check each terminal, check the bolt, if it's loose, and tighten it again. Check the reason if the cable temperature exceeds 40°C.

Charge and discharge status at the final stage can through capacity light to display. Please refer to 2-2-2 for the definition of capacity lights.

## 4.3 Trouble shooting steps

- Problem determination based on:

- 1) Whether the battery can turn on or not;
- 2) If battery is turned on, check the red light is off, flashing or lighting;
- 3) If the red light is off, check whether the battery can charge/discharge or not.

- Preliminary determination steps:

- 1) Battery cannot turn on, switch on the lights is all no lighting or flashing.

If the battery external switch is ON, the RUN light is flashing, and the external power supply voltage is 48V or more, the battery still unable to turn on, please contact.

- 2) The battery can be turned on, but red light is lighting, and cannot charge or discharge. If the red light is lighting, that means system is abnormal, please check values as following:

- a) Temperature: Above 50°C or under -10°C, the battery could not work.

Solution: to move battery to the normal operating temperature range between -10°C and 50°C

- b) Current: If current is greater than 100A, battery protection will turn on. Solution: Check whether

current is too large or not, if it is, to change the settings on power supply side.

c) High Voltage: If charging voltage above 54V, battery protection will turn on. Solution: Check whether voltage is too high or not, if it is, to change the settings on power supply side.

d) Low Voltage: When the battery discharges to 40.5V or less, battery protection will turn on. Solution: Charge the battery for some time, the red light turns off

Excluding the four points above, if the faulty is still cannot be located, turn off battery and repair.

- The battery cannot be charged or discharged

1) Cannot be charged:

Disconnect the power cables, measure voltage on power side, if the voltage is 52.5~54V, restart the battery, connect the power cable and try again, if still not work, turn off battery and contact.

2) Unable to discharge:

Disconnect the power cables and measure voltage on battery side, if it is under 40.5V, please charge the battery; if voltage is above 48V and still cannot discharge, turn off battery and contact

fault phenomenon	possible cause	handling method
Over voltage alarm	<ul style="list-style-type: none"> <li>● Overcharge voltage</li> <li>● There is a problem with cell consistency</li> </ul>	<ul style="list-style-type: none"> <li>● Check whether the charging voltage setting is reasonable. If not, adjust it according to the actual situation. ◦</li> <li>● If the battery consistency is faulty, contact after-sales engineers.</li> </ul>
Under voltage alarm	<ul style="list-style-type: none"> <li>● The AC power failure time is too long</li> <li>● Cell consistency problems, resulting in poor capacity.</li> </ul>	<ul style="list-style-type: none"> <li>● Charge the battery again. If the charge still fails, contact after-sales engineers.</li> <li>● If the battery consistency is faulty, contact after-sales engineers</li> </ul>
The buzzer kept ringing	<ul style="list-style-type: none"> <li>● The battery triggered an anti-theft lock</li> </ul>	<ul style="list-style-type: none"> <li>● Use anti-theft PC software to remove the lock</li> </ul>
power failure	<ul style="list-style-type: none"> <li>● After the over discharge of the battery cell, the battery voltage is lower than 2V without replenishment for a long time.</li> <li>● The voltage collection line of the battery cell is loose</li> </ul>	<ul style="list-style-type: none"> <li>● Contact after-sales engineers. ◦</li> </ul>
High temperature protection for charging or discharging	<ul style="list-style-type: none"> <li>● The ambient temperature is too high.</li> <li>● Heat sources exist around the battery.</li> </ul>	<ul style="list-style-type: none"> <li>● Check the ambient temperature alarm value (default: 0 ° C).</li> </ul>
Low temperature protection for charging or discharging	The ambient temperature is too low. Procedure	<ul style="list-style-type: none"> <li>● Check whether the upper battery temperature alarm value (53 ° C by default) is reasonable. If the alarm value is incorrect, adjust it according to the actual situation.</li> <li>● Check whether the battery cabin temperature control system is faulty. If yes, rectify the fault. This alarm is automatically cleared when the battery temperature returns to normal.</li> <li>● Check whether the BMS temperature sensor is faulty. If yes, replace the BMS temperature sensor.</li> </ul>

# 5

## TRANSPORTATION AND STORAGE

---

### 5.1 Transportation requirement

Battery via UN38.3 (UN38.3: Section 38.3 of the sixth Revised Edition of the Recommendations on the Transport of Dangerous Goods: Manual of Tests and Criteria) and SN/T 0370.2-2009 "Inspection Procedures for Packaging of Dangerous Goods for Export Part 2 Performance Inspection" certification (This product belongs to Class 9 dangerous goods)

The battery meets the transportation requirements of cars and ships. The transport box must be firm, and the outside of the box should comply with the provisions of the national standard and should be marked "handle with care" and "moisture-proof". Direct rain and snow and mechanical impact should be avoided during transportation.

### 5.2 Storage

#### ■ Storage Requirements

1. When storing batteries, place them according to the labels on the packing case. Do not place them upside down or on the side.
2. When packing cases are stacked, they shall comply with the packing requirements.
3. The storage environment requirements are as follows:
  - Ambient temperature  $-20\text{ }^{\circ}\text{C}$  to  $60\text{ }^{\circ}\text{C}$ . The recommended storage temperature is  $0\text{ }^{\circ}\text{C}$  to  $40\text{ }^{\circ}\text{C}$ .
  - Relative humidity  $\leq 95\%$ .
  - Storage battery should be at  $40\% \sim 80\%$  SOC.
  - The distance from the heat source (such as the heating device) must be at least 2m.

The warehouse manager should count the battery storage every month, and the batteries that are stored beyond the expiration date must be replenished in time.

- A dry, ventilated, and clean place.
- Avoid contact with corrosive substances or organic solvents (including gas).
- Avoid direct sunlight.

#### ■ Expired Storage Criteria

Storage temperature	Recharge interval	Recharge procedure for the single battery
<30°C	Every 6 months	1) Discharge with current 0.2C(A) to 0% SOC 2) Charge with current 0.2C(A) per battery for 2~4 hours
30°C-45°C	Every 3 months	
>45°C	Every 1 months	

## ■ Supplementary Power Processing

Check storage battery appearance, such as expansion, leakage, shell damage, scrap treatment. The positive and negative extremes of the battery are corroded. Sand them clean.

Use the charger to charge the battery with the following parameters.

Photoelectric parameter	Photoelectric parameter Settings
Recommend: charging voltage	52.8V (15S)
MAX charging voltage	54.0V (15S)
Charge current	It is recommended to use 0.2C with a maximum of 0.5C
End of charge condition	The charging current is less than 0.05C

After the battery is replenished, mark the last charge time and the next recharge time on the battery packing box.

# 6 ENVIRONMENT PROTECTION

## 6.1 Environmental Label

The product described in this manual does not contain toxic and hazardous substances or elements. It is a green product. It can be recycled after being discarded and should not be discarded at will. The environmental label shown in Table 6-1.

Table 6-1-1 Environmental label

Specification	Mark
LFELI 48V Series	

## 6.2 Recycle



■ This mark indicates that the product cannot be classified with other waste. In order to prevent potentially hazardous substances from hazardous waste disposal hazards to the environment and human health, please refer to the classification of waste recycling in order to promote the sustainable use of material resources.



In order to recycle the used equipment, please use the recycling system or contact the manufacturer or seller of the product or the local authority to manage the product.